

COUNTY COMMISSION OF LEWIS COUNTY

110 Center Avenue
Weston WV 26452
Phone:(304)269-8200
FAX: (304)269-2416
Email: lewiscountycommission@lewiscountywv.org
Website: lewiscountywv.org



COMMISSIONERS:
Agnes Queen, President
Rod Wyman, Commissioner
Bobby Stewart, Commissioner

**LEWIS COUNTY COMMISSION
110 CENTER AVENUE, 2ND FLOOR
WESTON, WV 26452
MEETING AGENDA
TUESDAY, October 10, 2023**

SILENT MEDITATION AND PLEDGE OF ALLEGIANCE

- 1. 10:00 AM** **Call Meeting to Order** (*action required*)
- 2. 10:05 AM** **John Breen, Lewis County Assessor**
RE: Exonerations, Consolidations, Apportionments
Draft copies will be available for review two business days prior to the meeting date. (*action required*)

APPOINTMENTS:

- 3. 10:10 AM** **No Appointments Scheduled**

CORRESPONDENCE & INFORMATION:

- 4. Upshur County Commission Meeting Agenda:** The October 12, 2023 Upshur County Commission meeting agenda is presented for review. (*information only*)
- 5. Jane Lew Public Service District:** The agenda and minutes of the September 14, 2023 meeting are presented for review. (*information only*)
- 6. Board(s) and Committee(s) Reports:** Commission will give reports on any Board(s) or committee(s) meeting attended, including: West Fork Conservation, Ireland Community Meeting, Lewis County Economic Development Authority, Lewis County High School Homecoming Parade and football game, WV Association of Counties Fall Board Meeting, Opioid Local Regional Meeting, Water Shed Dam Inspection, Rotary Club, National Association of Counties, Hubcap, Lewis County Community Foundation fund Advisory Meeting, Lewis County First, Lewis Upshur Gateway Community, 911 Advisory Board, T-Mobile Corporate Meeting, County Commission Association of WV strategic planning meeting, etc. (*action required*)

BUSINESS:

- 7. Lewis County Sheriff's Department Resignation:** Colton Jones submitted a letter of resignation from the position as Deputy Sheriff effective October 8, 2023. *(action required)*
- 8. Work Force West Virginia:** Consideration of Joseph Second, Senior Director of Operations at Mon Health Stonewall Jackson Memorial Hospital as a Board member. *(action required)*
- 9. Region VII:** Resolution of the LC Economic Development Authority approving invoices relating to services for the LC Phase I Water Extension Project. *(action required)*
- 10. Lewis-Gilmer County 911 Center & Emergency Management Office Change Orders:** The Commission will consider approving four change orders submitted by Dan Hill Construction/Silling Architects for project design changes and needs at the new 911 center. *(action required)*
- 11. Lewis County Economic Development Authority:** Ray Smith, Director, submits the following persons for consideration of appointment to the LC Economic Development Authority Board; Rod Wyman, term expiring 12-31-2023 and Bobby Stewart, term expiring 12-31-2025. *(action required)*
- 12. Lewis Upshur Animal Control Facility Request:** The Lewis Upshur Animal Control Facility requests \$5,00.00 from the spay and neuter account. *(action required)*
- 13. David B. Gosa, Sheriff of Lewis County presents the 2022 Delinquent Tax list for approval by the Lewis County Commission:** If approved this list will be published in the Weston Democrat. *(action required)*
- 14. Time Sheets and Leave Requests:** Tina Helmick Time Sheet, David Reed Annual Leave, Barbara Winans Annual Leave, Sherry Rogers Annual Leave, Sick Leave, Garry DeMoss Annual Leave, Steve Money Penny Annual Leave *(action required)*

ACTIONS, ESTATE SETTLEMENTS, ORDERS AND PAYMENT OF EXPENDITURES:

- 15. Actions of the Clerk:** County Clerk Cynthia S. Rowan presents actions of the clerk in recess of the county commission for approval. Draft copies will be available for review upon request two business days prior to the meeting date. *(action required)*
- 16. Approval of Estates:** County Clerk Cynthia S. Rowan presents the estates ready for settlement to the Lewis County Commission for approval. Draft copies will be available for review upon request two business days prior to the meeting date. *(action required)*
- 17. Presentation by the County Clerk of the Orders of Prior Meeting(s):** The Lewis County Clerk presents the Orders (minutes) of previous Lewis County Commission meeting(s) for approval. Draft copies will be available for review upon request two business days prior to the meeting date. *(action required)*
- 18. Expenses for the Current Period Presented for Consideration of Payment:** Draft copies will be available for review upon request two business days prior to the meeting date. *(action required)*

ADJOURNMENT:

- 19. With no further action being required by the Lewis County Commission the meeting will be adjourned.** *(action required)*

LEWIS COUNTY COMMISSION MEETING MANAGEMENT

- Regular meeting agendas will be posted and available to the public before closure two (2) business days prior to the meeting date.
- Agenda matters to be reviewed and/or considered during the meeting are at the discretion of the Lewis County Commission.
- Appointments to speak with the county commission must be scheduled before 10 AM three (3) business days prior to the meeting. Appointments will be given up to a ten (10) minute time allowance.
- Agenda items may require an executive session.
- Open discussion by Commission unless executive session is motioned per WV Code §6-9A-4.
- Input or recommendation from constitutional officers, staff or public that is not listed by name on the agenda will only be allowed if requested by the commission or required by statute.
- Those not scheduled on the agenda may sign up for public comment at a minimum fifteen (15) minutes prior to the start of the meeting. Public comment is limited to five (5) minutes per speaker.
- Motion required for consideration of vote.
- All votes unanimous unless otherwise stated.
- Roberts Rules of Order is utilized as a guide only. The Commission controls meeting management, discussion and input.
- Commissioners may participate and vote via conference call if two (2) commissioners are in attendance.

Additional Notices

Upshur County Commission Meeting Agenda

Agenda packets are available electronically at http://www.upshurcounty.org/agenda_and_minutes/index.php or by request to the Upshur County Commission Office at 304-472-0535.

- Location: Upshur County Courthouse Annex
If you prefer to participate by telephone, please dial 1-408-650-3123 Access Code: [272 564 045](tel:272564045) to enter the conference call.
- Date of Meeting: October 5, 2023
- 9:00 a.m. Moment of Silent Meditation --- Pledge of Allegiance
Approval of Minutes:
 - September 21, 2023
- 10:00 a.m. Public hearing to consider evidence related to the possible closure of an unused travel way identified on the Ballah View Addition. This application has been submitted by Cornerstone Community Church per WV Code §7-1-3h. [Page 4](#)
- 1:00 p.m. Meeting with Buckhannon City Council regarding property matters.
Item may lead to Executive Session per WV Code §6-9A-4

Items for Discussion / Action / Approval:

1. Review and signature of Renewal Agreement between the Upshur County Commission and Quality Home & Office Cleaning for janitorial services. Per the renewal clause, Owner and Contractor agree all terms set forth in the Agreement dated October 14, 2021 are in full force and effect for another one-year period effective November 1, 2023 and continuing through October 31, 2024. Owner shall pay the Contractor no more than the sum of \$40,664.40 for the outlined general janitorial services. * [Pages 5-10](#)
2. Consider approval of a Property Use Agreement renewal between the Upshur County Commission and the Upshur County Youth Soccer Association Inc. to lease the 13.84-acre Wellness Complex Property located on Brushy Fork. A Certificate of Liability insurance has been received. * [Pages 11-20](#)
3. Consider selling a tract of land located in the town of Selbyville, Banks District, Upshur County, to the Selbyville Volunteer Fire Department. The property is more particularly described in the description of survey prepared by William Malcomb dated 8/3/2023. * [Page 21](#)
4. Consider a request from Senator Robert L. Karnes for a one-time financial contribution of \$1,000 to support a USDA project to erect a high tunnel at Buckhannon-Upshur Middle School. * [Pages 22-23](#)
5. Approval of Requests for Bids and Minimum Vehicle Specifications for one truck for the Upshur County Maintenance Department. Sealed proposals must be received no later than 4:00 p.m. on Wednesday, November 1, 2023 at the Administrative Annex located at 91 West Main Street, Suite 101. Bids received by the deadline will be publicly opened, reviewed and read aloud by the Commission on Thursday, November 2, 2023. * [Pages 24-25](#)
6. Review and signature of the Upshur County Fire Board, Inc. incentive for Tax Deputies who process Fire Fees collected in the Sheriff's Office. This supplement will begin with the first pay period in October and will be contingent upon an annual review each year. *

Item may lead to Executive Session per WV Code §6-9A-4 (A)

[Under separate cover](#)

7. Approval of Lewis-Upshur Animal Control Facility volunteer:
a) Brianna Pearson* [Under separate cover](#)
8. Consider reappointment of Jacob Mills as community representative to the Buckhannon Upshur Parks and Recreation Advisory Board. Upon approval, the term will be effective immediately through June 30, 2025. *
[Under separate cover](#)
9. Consider appointment of Randy Kirchberg as County Representative to the vacant seat on the Upshur County Farmland Protection Board. Upon approval, the term will be effective immediately through June 30, 2027. *
[Under separate cover](#)
10. Consider resignation of two employees. *
Item may lead to Executive Session per WV Code §6-9A-4 A [Under separate cover](#)
11. Approve retirement of an employee. *
Item may lead to Executive Session per WV Code §6-9A-4 [Under separate cover](#)
12. Approval of an advertisement for a full-time Deputy Clerk-Bookkeeper in the Upshur County Clerk's Office. Applications received by 4:00 p.m. on Friday, October 27, 2023 will be reviewed; however, applications may be considered until position is filled. * [Page 26](#)
13. Correspondence from Tabatha R. Perry, County Administrator, requesting the part-time employment of Ashley Runyon and Joan McDaniels as James W. Curry Library Attendants, effective October 8, 2023. Upon approval, each employee will work no more than 19.5 hours per week. *
Item may lead to Executive Session per WV Code §6-9A-4 A [Under separate cover](#)
14. Approve Invoices for Payment, Purchase Card Invoices for Payment, Budget Revisions / Financial Reports or Information, Correction of Erroneous Assessments, Exonerations/Refunds, Grant Updates / Requests for Reimbursements, Final Settlements, Vacation Orders, Consolidation of Land Tracts, Facility Maintenance Concerns or Updates, Road Name Requests, Project Reports / Updates, Request to Attend Meetings, Request for Day(s) Off.

For Your Information:**(Certain Items May Require Discussion, Action and/or Approval by the Commission)**

1. Correspondence from Governor Jim Justice announcing the first allocation of funds from the All County Fire Protection Fund established from Senate Bill 1021 passed on August 8, 2023 by the West Virginia Legislature. [Pages 27-36](#)
2. Upshur County Sheriff's Financial Statement for period ending August, 2023. [Pages 37-38](#)
3. Memorandum from Mary A. Hatfield, Assistant Director of Justice and Community Services notifying entities effective October 1, 2023 all federal grant funds administered by the Justice and Community Services (JCS) Section will be issued to subrecipients on a monthly, reimbursement-only basis. [Pages 39-40](#)
4. Memorandum from Mary A. Hatfield, Assistant Director of Justice and Community Services, outlining the procedures for compliance in reporting requirements found within WV Code §12-4-14 also known as the West Virginia Grant Transparency and Accountability Act. [Pages 41-42](#)
5. Upshur County Mileage Reports – August, 2023
- Addressing and Mapping [Page 43](#)
 - Dog Pound [Page 44](#)
 - Emergency Management [Page 45](#)
 - Maintenance [Pages 46-48](#)
 - Parks & Recreation [Page 49](#)
 - Sheriff [Page 50](#)

- Upshur 911

Page 51

6. Public Notices:

a) Newsletters and/or Event Notifications:

- None

b) Agendas and/or Notice of Meetings:

- | | | |
|---|------------------|---------|
| • Upshur County Youth Camp Board | August 17, 2023 | Page 52 |
| • Elkins Road Public Service District | October 3, 2023 | Page 53 |
| • Upshur County Safe Structures and Sites | October 12, 2023 | Page 54 |
| • Upshur County Farmland Protection Board | October 17, 2023 | Page 55 |

Meeting Minutes:

- | | | |
|---------------------------------------|-----------------|-------------|
| • Upshur County Solid Waste Authority | | |
| ○ Board Minutes | August 14, 2023 | Page 56 |
| ○ Director's Report | August 14, 2023 | Page 57 |
| • Upshur County Fire Board Meeting | August 15, 2023 | Page 58 |
| • Upshur County Youth Camp Board | August 17, 2023 | Pages 59-60 |

c) Meetings: *Dates and times of monthly board meetings are viewable at:

<http://cms4.revize.com/revize/upshurwv/calendar.php>

or go to www.upshurcounty.org and click on the board meetings calendar box on the main page.

7. Appointments Needed or Upcoming:

- None

****If you are interested in serving on an Upshur County board, please submit your letter of interest to the Commission Office at 91 W. Main St., Suite 101, Buckhannon, WV 26201 or chughes@upshurcounty.org. Upcoming term expirations are listed in this section of the agenda; however, letters of interest can be submitted at any time. Letters of interest for boards that do not currently have a vacancy will be held until a vacancy occurs. Please note that submitting a letter of interest does not guarantee appointment. ****

Newsletters and/or Event Notifications, Agendas and/or Notices of Meetings, Meeting Minutes and Scheduled Meetings can all be found by visiting: http://www.upshurcounty.org/agenda_and_minutes/index.php

Tabled Items

(Certain Items May Require Discussion, Action and/or Approval by the Commission)

None

Next Regular Meeting of the Upshur County Commission
October 19, 2023 --- 9:00 a.m.
Upshur County Courthouse Annex
The meeting scheduled for October 12th, 2023 has been cancelled.

Jane Lew Public Service District

70 Park Avenue
Jane Lew, WV 26378

Minutes of Regular Meeting September 14, 2023

Present: Bradley Foster (Chairman), Nancy Gee (Board), Oscar Mills (Board), Stephanie Snow-McKisic, General Manager.
Guests:
Absent:

- I. **Call to Order** The meeting was called to order at 4:02 pm Chairman Foster.

~ ROUTINE MONTHLY BUSINESS ~

- II. **Minutes: (8/10/23)**

MOTION: (Gee/Foster) to approve attached Minutes of 8/10/23 regular meeting. **[Carried Unanimously]**

- III. **General Manager's August Reports (Snow-McKisic)**

A. **WATER:**

1. Bills (Attached)

MOTION: (Mills/Foster) to ratify payment of attached list of water invoices for August 2023. **[Carried Unanimously]**

2. Treasury Report (Attached)

MOTION: (Gee/Mills) to approve attached Water Treasury Report for August 2023. **[Carried Unanimously]**

3. Water Adjustments Report (Attached)

MOTION: (Foster/Gee) to approve attached Water Adjustments Report for August 2023. **[Carried Unanimously]**

4. Water Purchase, Sales & Loss Report (Attached)

MOTION: (Mills/Foster) to approve attached Water Purchase, Sales & Loss Report for August 2023. **[Carried Unanimously]**

5. Water Preventive Maintenance Report -

- a) Lines - **Walked lines looking for leaks.**
- b) Loss Prevention/leak detection - **water loss 4%**
- c) Fire + Flushing Hydrants [57 + 25] - **Number, trim around, map and record changes.**
- d) Valves [148] **Worked Valves for leak detection-Exercised 1 full cycle/ Valves to be exercised again in September.**
 - a. Meters [705] - **Total of 8 new meters installed (5 for Snider, Bills Run, Clay Lick and Jesse's Run)**
 - e) Booster Stations [3] - **checked**
 - f) Tanks [2] - **Mow around tanks and during the growing season.**
 - g) Office Furnace + A/C - **nothing needed**
 - h) Vehicles [½ 2019 Truck, ½ crane truck, + ½ Buggy] - **nothing**
 - i) Generators [1 big port + 2 small] - **exercised generator**
 - j) Expensive Equipment [Mower] - **nothing**
 - k) Critical Inventory - **nothing**
 - l) Other - **nothing**

6. Water System Water Leak Detection Report (*finding & repairing actual leaks*) – **Nothing.**
7. Water System Repairs Report (*fixing unplanned breakdowns*) – **Nothing**
8. Cross-Connections/Backflow Report – **ongoing**
9. New Non-Project Water Taps/Road bores – **none**
10. Other –

Water Assignments

None

B. WASTEWATER:

1. Wastewater Bills (Attached)

MOTION: (Gee/Foster) to ratify payment of list of Sewer invoices for August, 2023. **[Carried Unanimously]**

2. Wastewater Treasury Report (Attached)

MOTION: (Mills/Gee) to approve Sewer Treasury Report for August 2023. **[Carried Unanimously]**

3. Wastewater Adjustments Report (Attached)

MOTION: (Foster/Mills) to approve Sewer Adjustments Report for August 2023. **[Carried Unanimously]**

4. Wastewater Treatment Purchase, Sales & Loss Report (Attached) -

MOTION: (Gee/Foster) to approve Sewer Treatment Purchase, Sales & Loss Report of August 2023. **[Carried Unanimously]**

5. Wastewater Preventive Maintenance Report (attached)

- a) Lines– **Flushed Steve Light’s house line towards the main. Flushed line at 321 Ridgeway. Flushed line at 164 Virginia St. Flushed, planned repair.**
- b) I&I Prevention - **nothing**
- c) Manholes [643] –**Number, map and record when changes occur. Mow during the growing season. Planned repair**
- d) Duplex + ABS Grinder Pumps [5 + 2] – **amped and enzymed every Friday**
- e) Lift Stations [10 total] – **Inspect pit and floats weekly. Clean floats as needed. Inspect lightbulbs weekly. Amped & Enzymed every Friday/ Changed Charts and record meter readings/Record run times/Trim and mow during growing season.**
- f) Bar Screen [1] – **clean bar screens every week.**
- g) Vehicles – [$\frac{1}{2}$ '19 Ford Truck, $\frac{1}{2}$ crane truck & $\frac{1}{2}$ Buggy] – **Wash monthly, change oil, rotate tires, brakes and rotors as needed.**
- h) Classroom Furnace & A/C – **nothing**
- i) Expensive Equipment [mower] – **nothing**
- j) Critical Inventory – **nothing.**
- k) Other- **nothing.**

6. Wastewater Repairs Report (attached) **E-1 Pump at the end of Sycamore Lick (Janet McIntyre’s) kicked off when the electric shut off. Dispatched and fixed the issue. 2x**

7. New Non-Project Sewer Taps/Road Bores – **Nothing**

8. Other – **Nothing**

- IV. PSD Policies and Job Descriptions (Snow-McKisic) – Nothing
- V. Personnel Matters (Snow-McKisic) – Nothing
- VI. Announcements:-Water on the Mountain was a success. There are a few bugs to be worked out but the venue was very nice and the classes were very informative.
- VII. Correspondence:
 - A. Email from Jim Kelsh-SOS response to Staff's First Data Request Aug 17, 2023

~~ OLD BUSINESS ~~

- VIII. Request to Purchase Property beside Wastewater Plant (Snow-McKisic) – All paperwork has been submitted to e PSC and we are waiting on approval. We may not get a response until October. Email from Jim Kelsh-SOS response to Staff's First Data Request Aug 17, 2023
- IX. Rate Increase- 19A Application submitted to the PSC. Awaiting approval.
- X. LCRR- Lead and Copper information will be needed for every home. We will be adding messages to the bills and sending out an automated message for customers to watch for the forms in the mail, fill them out and turn them in to the office. If needed, we will hold a town hall meeting to answer any questions for the public. We will also go d2d and tag.

Assignments

- ✓ *Snow-McKisic to keep Atty. Kelsh apprised of property matters*

~~ NEW BUSINESS ~~

- XI. State Audit Procurement Process. – All bids have been received. The process was reviewed. The Committee will consist of all 3 Board Members, plus Stephanie Snow-McKisic and Vickie Perrine. The firms will be scored at the October meeting.
- XII. Late Received Agenda Items (Snow-McKisic) – none
- XIII. Adjournment: The meeting was adjourned by Chairman Foster at 4:34pm.

Attachments:

- Aug 2023 Bills Paid (Water/Wastewater)
- Aug 2023 Treasury Reports (Water/Wastewater)
- Aug 2023 Adjustments Reports (Water/Wastewater)
- Aug 2023 Water/Wastewater Treatment Purchase, Sales & Loss Report
- Correspondence

E-Copies of Unapproved Minutes Sent to:

- James V. Kelsh, PSD Attorney (Bowles Rice)
- PSD Office
- Board Members
- LC Commission
- Ray Smith



Lewis County Sheriff's Department



Deputy C.C. Jones

117 Court Ave, Weston, WV 26452
Phone: (304) 269-8251

Email: cjones@lewiscountywv.org
Fax: (304) 269-2644

Two Week Notice Letter

09/22/2023

Lewis County Sheriff's Department

117 Court Ave
Weston, WV 26452

Sheriff D. Gosa,

Please accept this letter as my formal resignation from my position as Deputy Sheriff at the Lewis County Sheriff's Department, effective October 8, 2023.

I appreciate the opportunities for growth and development you have provided during my tenure. Please let me know how I can be of help during the transition period. I wish you and the Sheriff's Department the very best going forward.

Thank you,

Colton Jones

A handwritten signature in blue ink, appearing to read 'Colton Jones', with a long horizontal flourish extending to the right.



NOMINATION FORM

Region VI Workforce Development Board

WORKFORCE West Virginia

Please send a copy to: Region VI Workforce Development Board, 17 Middletown Road, White Hall, WV 26554

Name (First, MI, Last) Joseph P. Second, MHA		Title Senior Director Operations		(Agency/Business Name): Mon Health Stonewall Jackson Memorial Hospital		
Street Address 233 Park Blvd			WDB Sector Representation: a. Business _X_ b. Labor Organization ** ___ c. Apprenticeship ** ___ d. Community Based Org. (CBO) ___ e. Ad Ed/Family Literacy ___ f. Higher Education ___ g. Economic Development. ___ h. Wagner-Peyser ___ i. Rehabilitation Services ___ j. Youth ___ k. Other ___			
City Clarksburg	County Harrison					
State WV	ZIP 26301					
Home Phone (include area code) 304.838.3384		Work Phone (include area code) 304.269.8149				
FAX		Cell phone (include area code) 304.838.3384				
E-Mail Joe.Second@VandaliaHealth.Org			Nomination <input checked="" type="checkbox"/> New <input type="checkbox"/> Reappointment			
			** Organized Labor or Apprenticeship Organization: Please Specify local labor federation or building and trades council of affiliation <div style="text-align: center; font-size: 1.5em;">N/A</div>			
Nominator (Applicable to Business & Labor Representatives only) <i>I hereby recommend the above named person for membership on the Local Workforce Development Board for Region VI service area.</i>			Action by Local Elected Official Subject to the requirements of Section 107(b)(1) and (2) of the Workforce Innovation and Opportunity Act of 2014, the person nominated herein has been duly appointed to the Local Workforce Development Board by the Chief Elected Officials of Region VI.			
Signature _____ Date _____ Printed/Typed Name & Title of Nominator _____ Nominator Organization _____			Term of Appointment: FROM <u>9/15/23</u> TO <u>9/15/26</u> Signature of Chief Elected Official _____ Date _____			
Phone _____ FAX _____ E-Mail _____			Certification of Chief Elected Official Chair <div style="text-align: center;"> Ernest VanRulden Signature of Chair _____ Date <u>15 Sept 2023</u> </div>			

Region VI Workforce Development Board

17 Middletown Road
White Hall, WV 26554
p 304.368.9530
f 304.368.9532
WV Relay 7-1-1
www.regionviwv.org

September 20, 2023

Commissioner Rod Wyman
110 Center Ave. 2nd Floor
Weston, WV 26452

Dear Commissioner Wyman,

At our LEO Board meeting held September 15th, 2023 approval was given by vote to appoint Joseph Second, Senior Director of Operations at Mon Health Stonewall Jackson Memorial Hospital as a Full Board member. Since the hospital is in Lewis County, your signature is required. This is in compliance with the WIOA of 2014. Please sign and date where indicated and return the Nomination Form in the envelope provided.

Please return it at your earliest convenience. Thank you for your attention to this matter.

Sincerely,



Kathi Waters
Program/Administrative Assistant
Enclosures (2)

RESOLUTION
of the
LEWIS COUNTY ECONOMIC DEVELOPMENT AUTHORITY, WEST VIRGINIA
APPROVING INVOICES RELATING TO SERVICES
for the
LEWIS COUNTY PHASE I WATER EXTENSION PROJECT
IJDC PROJECT # 2016W-1630
RFP #04
and

AUTHORIZING PAYMENT THEREOF

WHEREAS, the Lewis County Economic Development Authority has reviewed the invoices attached hereto and incorporated herein by reference relating to the Lewis County Phase I Water Extension Project funded in part by the Community Development Block Grant (“CDBG”), the Infrastructure & Jobs Development Council (“IJDC”), West Virginia American Water Company (“WVAWC”), the Water Development Authority (“WDA”), Lewis County Commission (“LCC”) and Lewis County Economic Development Authority (“LCEDA”) and find as follows:

- A. That none of the items for which payment is proposed to be made has been requested from another funding source;
- B. That each item for which the payment is proposed to be paid is or was necessary in connection with the Project and constitutes a cost of the Project;
- C. That each of such costs has been otherwise properly incurred;
- D. That the payment for each of the items proposed is due and owed.

NOW, THEREFORE, BE IT RESOLVED that the Lewis County Economic Development Authority hereby approves and authorizes payment of the following invoice:

Vendor	Invoice #	Invoice Date	CDBG	IJDC Loan	IJDC Grant	WVAW	EEGF	LCC	LCEDA	Total
RHP Resources & Consulting – Lewis County EDA Reimbursement	1113	7/5/2023	\$3,200.00	\$0.00	\$0.00	\$0.00	\$0.00	\$0.00	\$0.00	\$3,200.00
RHP Resources & Consulting – Lewis County EDA Reimbursement	1116	8/29/2023	\$2,800.00	\$0.00	\$0.00	\$0.00	\$0.00	\$0.00	\$0.00	\$2,800.00
RHP Resources & Consulting – Lewis County EDA Reimbursement	1117	9/18/2023	\$2,000.00	\$0.00	\$0.00	\$0.00	\$0.00	\$0.00	\$0.00	\$2,000.00
Region VII Planning & Development Council	451-7	6/30/2023	\$3,241.47	\$0.00	\$0.00	\$0.00	\$0.00	\$0.00	\$0.00	\$3,241.47
		TOTALS:	\$11,241.47	\$0.00	\$0.00	\$0.00	\$0.00	\$0.00	\$0.00	\$11,241.47

ADOPTED BY the Lewis County Economic Development Authority at a meeting held on the 27th day of September, 2023.

Lewis County Economic Development Authority

By: _____
Stephanie Wolverton, President

451-Lewis County Phase I Water Extension Project

Expenditure Schedule #4

September 27, 2023

Edited by: Carrie Wallace
 Printed: 09/18/2023 @ 11:15 AM

Total Project	Approved Budget	Adjustments	Revised Budget	Paid Prior to this Draw	Requested this Draw	Requested to Date	Balance Remaining
CONSTRUCTION							
Contract #1 -	\$ 8,843,367.00	\$ (528,061.00)	\$ 8,315,306.00	\$ -	\$ -	\$ -	\$ 8,315,306.00
Contract #1 - Change Order #1							
Contract #1 - Change Order #2							
Contract #1 - Change Order #3							
Contract #2 -	\$ -	\$ -	\$ -	\$ -	\$ -	\$ -	\$ -
Contract #2 - Change Order #							
CONTINGENCY (Post-Bid 5%)	\$ 677,998.00	\$ 111,425.00	\$ 789,423.00	\$ -	\$ -	\$ -	\$ 789,423.00
TOTAL CONSTRUCTION COSTS	\$ 9,521,365.00	\$ (416,636.00)	\$ 9,104,729.00	\$ -	\$ -	\$ -	\$ 9,104,729.00
ENGINEERING SERVICES							
(The Thrasher Group)							
Study & Report Phase	\$ 50,000.00	\$ -	\$ 50,000.00	\$ 50,000.00	\$ -	\$ 50,000.00	\$ -
Design (Preliminary)	\$ 195,000.00	\$ -	\$ 195,000.00	\$ 175,500.00	\$ -	\$ 175,500.00	\$ 19,500.00
Design (Final)	\$ 215,000.00	\$ -	\$ 215,000.00	\$ -	\$ -	\$ -	\$ 215,000.00
Bidding & Negotiating	\$ 15,000.00	\$ -	\$ 15,000.00	\$ -	\$ -	\$ -	\$ 15,000.00
Engineering During Construction	\$ 65,000.00	\$ -	\$ 65,000.00	\$ -	\$ -	\$ -	\$ 65,000.00
Resident Project Representative	\$ 170,000.00	\$ -	\$ 170,000.00	\$ -	\$ -	\$ -	\$ 170,000.00
	\$ -	\$ -	\$ -	\$ -	\$ -	\$ -	\$ -
Special Services							
Funding Applications (Preparation of)	\$ 7,000.00	\$ -	\$ 7,000.00	\$ 7,000.00	\$ -	\$ 7,000.00	\$ -
Expert Witness (Before Agencies)	\$ 7,000.00	\$ -	\$ 7,000.00	\$ -	\$ -	\$ -	\$ 7,000.00
PSC Submission	\$ 5,000.00	\$ -	\$ 5,000.00	\$ -	\$ -	\$ -	\$ 5,000.00
Topographic Survey (Land Plan & Partion)	\$ 13,000.00	\$ -	\$ 13,000.00	\$ -	\$ -	\$ -	\$ 13,000.00
Land & ROW Surveys (Survey & Ease Prep)	\$ 7,000.00	\$ -	\$ 7,000.00	\$ -	\$ -	\$ -	\$ 7,000.00
Aerial Photo/Mapping (Eng Survey&Topo)	\$ 12,000.00	\$ -	\$ 12,000.00	\$ 12,000.00	\$ -	\$ 12,000.00	\$ -
Construction Surveys	\$ 4,000.00	\$ -	\$ 4,000.00	\$ -	\$ -	\$ -	\$ 4,000.00
Permit (Env'l Assessment & Impact St)	\$ 10,000.00	\$ -	\$ 10,000.00	\$ -	\$ -	\$ -	\$ 10,000.00
TOTAL ENGINEERING COSTS	\$ 775,000.00	\$ -	\$ 775,000.00	\$ 244,500.00	\$ -	\$ 244,500.00	\$ 530,500.00
PROFESSIONAL SERVICES and OTHER							
Administrative (Region VII)	\$ 125,000.00	\$ -	\$ 125,000.00	\$ 34,433.56	\$ 3,241.47	\$ 37,675.03	\$ 87,324.97
	\$ -	\$ -	\$ -	\$ -	\$ -	\$ -	\$ -
Accounting (Bennett&Dobbins)	\$ 40,000.00	\$ (31,500.00)	\$ 8,500.00	\$ -	\$ -	\$ -	\$ 8,500.00
	\$ -	\$ -	\$ -	\$ -	\$ -	\$ -	\$ -
Permits/Ads/Fees	\$ 27,350.00	\$ -	\$ 27,350.00	\$ -	\$ -	\$ -	\$ 27,350.00
Lands/ROW	\$ 110,000.00	\$ 110,000.00	\$ 110,000.00	\$ 12,800.00	\$ 8,000.00	\$ 20,800.00	\$ 89,200.00
Legal (Local) (Bowles&Rice)	\$ 15,000.00	\$ 40,000.00	\$ 55,000.00	\$ -	\$ -	\$ -	\$ 55,000.00
Legal (PSC) (Steptoe&Johnson)	\$ 30,000.00	\$ (15,000.00)	\$ 15,000.00	\$ -	\$ -	\$ -	\$ 15,000.00
ROW Agent (Company Name)	\$ -	\$ -	\$ -	\$ -	\$ -	\$ -	\$ -
Capitalized Interest	\$ -	\$ -	\$ -	\$ -	\$ -	\$ -	\$ -
Registrar	\$ -	\$ -	\$ -	\$ -	\$ -	\$ -	\$ -
Bond Counsel (White Law)	\$ 50,000.00	\$ (30,000.00)	\$ 20,000.00	\$ -	\$ -	\$ -	\$ 20,000.00
Project Contingency	\$ -	\$ 36,500.00	\$ 36,500.00	\$ -	\$ -	\$ -	\$ 36,500.00
TOTALS:	\$ 10,693,715.00	\$ (306,636.00)	\$ 10,277,079.00	\$ 291,733.56	\$ 11,241.47	\$ 302,975.03	\$ 9,974,103.97

451-Lewis County Phase I Water Extension Project

Expenditure Schedule #4

September 27, 2023

Edited by: Carrie Wallace

CDBG	Approved Budget	Adjustments	Revised Budget	Paid Prior to this Draw	Requested this Draw	Requested to Date	Balance Remaining
CONSTRUCTION							
Contract #1 -	\$ 1,500,000.00	\$ (235,000.00)	\$ 1,265,000.00	\$ -	\$ -	\$ -	\$ 1,265,000.00
Contract #1 - Change Order #1		\$ -					
Contract #1 - Change Order #2		\$ -					
Contract #1 - Change Order #3		\$ -					
Contract #2 -	\$ -	\$ -	\$ -	\$ -	\$ -	\$ -	\$ -
Contract #2 - Change Order #		\$ -					
CONTINGENCY (Post-Bid 5%)	\$ -	\$ -	\$ -	\$ -	\$ -	\$ -	\$ -
TOTAL CONSTRUCTION COSTS	\$ 1,500,000.00	\$ (235,000.00)	\$ 1,265,000.00	\$ -	\$ -	\$ -	\$ 1,265,000.00
ENGINEERING SERVICES							
(The Thrasher Group)							
Study & Report Phase	\$ 50,000.00	\$ -	\$ 50,000.00	\$ 50,000.00	\$ -	\$ 50,000.00	\$ -
Design (Preliminary)	\$ 195,000.00	\$ -	\$ 195,000.00	\$ 175,500.00	\$ -	\$ 175,500.00	\$ 19,500.00
Design (Final)	\$ 203,000.00	\$ -	\$ 203,000.00	\$ -	\$ -	\$ -	\$ 203,000.00
Bidding & Negotiating	\$ -	\$ -	\$ -	\$ -	\$ -	\$ -	\$ -
Engineering During Construction	\$ -	\$ -	\$ -	\$ -	\$ -	\$ -	\$ -
Resident Project Representative	\$ -	\$ -	\$ -	\$ -	\$ -	\$ -	\$ -
	\$ -	\$ -	\$ -	\$ -	\$ -	\$ -	\$ -
Special Services							
Funding Applications (Preparation of)	\$ 7,000.00	\$ -	\$ 7,000.00	\$ 7,000.00	\$ -	\$ 7,000.00	\$ -
Expert Witness (Before Agencies)	\$ 7,000.00	\$ -	\$ 7,000.00	\$ -	\$ -	\$ -	\$ 7,000.00
PSC Submission	\$ 5,000.00	\$ -	\$ 5,000.00	\$ -	\$ -	\$ -	\$ 5,000.00
Topographic Survey (Land Plan & Partion)	\$ 11,000.00	\$ -	\$ 11,000.00	\$ -	\$ -	\$ -	\$ 11,000.00
Land & ROW Surveys (Survey & Ease Prep)	\$ -	\$ -	\$ -	\$ -	\$ -	\$ -	\$ -
Aerial Photo/Mapping (Eng Survey&Topo)	\$ 12,000.00	\$ -	\$ 12,000.00	\$ 12,000.00	\$ -	\$ 12,000.00	\$ -
Construction Surveys	\$ -	\$ -	\$ -	\$ -	\$ -	\$ -	\$ -
Permit (Env'l Assessment & Impact St)	\$ 10,000.00	\$ -	\$ 10,000.00	\$ -	\$ -	\$ -	\$ 10,000.00
TOTAL ENGINEERING COSTS	\$ 500,000.00	\$ -	\$ 500,000.00	\$ 244,500.00	\$ -	\$ 244,500.00	\$ 255,500.00
PROFESSIONAL SERVICES and OTHER							
Administrative (Region VII)	\$ -	\$ 125,000.00	\$ 125,000.00	\$ 34,433.56	\$ 3,241.47	\$ 37,675.03	\$ 87,324.97
	\$ -	\$ -	\$ -	\$ -	\$ -	\$ -	\$ -
Accounting (Bennett&Dobbins)	\$ -	\$ -	\$ -	\$ -	\$ -	\$ -	\$ -
	\$ -	\$ -	\$ -	\$ -	\$ -	\$ -	\$ -
Permits/Ads/Fees	\$ -	\$ -	\$ -	\$ -	\$ -	\$ -	\$ -
Lands/ROW	\$ -	\$ 110,000.00	\$ 110,000.00	\$ 12,800.00	\$ 8,000.00	\$ 20,800.00	\$ 89,200.00
Legal (Local) (Bowles&Rice)	\$ -	\$ -	\$ -	\$ -	\$ -	\$ -	\$ -
Legal (PSC) (Steptoe&Johnson)	\$ -	\$ -	\$ -	\$ -	\$ -	\$ -	\$ -
ROW Agent (Company Name)	\$ -	\$ -	\$ -	\$ -	\$ -	\$ -	\$ -
Capitalized Interest	\$ -	\$ -	\$ -	\$ -	\$ -	\$ -	\$ -
Registrar	\$ -	\$ -	\$ -	\$ -	\$ -	\$ -	\$ -
Bond Counsel (White Law)	\$ -	\$ -	\$ -	\$ -	\$ -	\$ -	\$ -
Project Contingency	\$ -	\$ -	\$ -	\$ -	\$ -	\$ -	\$ -
TOTALS:	\$ 2,000,000.00	\$ -	\$ 2,000,000.00	\$ 291,733.56	\$ 11,241.47	\$ 302,975.03	\$ 1,697,024.97

**Community Development Block Grant Program
REQUEST FOR PAYMENT**

TO: West Virginia Development Office
Building 3, Room 700
1900 Kanawha Boulevard, East
Charleston, WV 25305-0311
304.558.2234

FROM: Lewis Co Commission
110 Center Ave
Weston, WV 26452
ph. (304) 269-8200 fax. (304) 269-2416
lewiscountycommission@lewiscountywv.org

Project Name	Lewis County Phase I Water Extension Project	Project #	20CDBG0009
---------------------	--	------------------	------------

Invoice #	22779-3	% of CDBG Funds Expended	15.1%
------------------	---------	---------------------------------	-------

Time Period Covered by this Request:	04/01/2023	To:	09/18/2023
---	------------	------------	------------

Amount of CDBG Funds on hand at the time of this Request					\$ -	
COST CATEGORIES	APPROVED BUDGET AMOUNT	AMOUNT REQUESTED TO DATE	AMOUNT REQUESTED THIS DRAW	TOTAL AMOUNT REQUESTED	AMOUNT DISBURSED TO DATE	BALANCE
Administration	\$ 125,000.00	\$ 34,433.56	\$ 3,241.47	\$ 37,675.03	\$ 34,433.56	\$ 87,324.97
Accounting						
Arch/Engineering	\$ 500,000.00	\$ 244,500.00	\$ -	\$ 244,500.00	\$ 244,500.00	\$ 255,500.00
Land Acquisition	\$ 110,000.00	\$ 12,800.00	\$ 8,000.00	\$ 20,800.00	\$ 12,800.00	\$ 89,200.00
Construction	\$ 1,265,000.00	\$ -	\$ -	\$ -	\$ -	\$ 1,265,000.00
Permits/Fees						
Legal						
Planning						
SUB-TOTAL:	\$ 2,000,000.00	\$ 291,733.56	\$ 11,241.47	\$ 302,975.03	\$ 291,733.56	\$ 1,697,024.97
Less Income				\$ -		
TOTAL:	\$ 2,000,000.00	\$ 291,733.56	\$ 11,241.47	\$ 302,975.03	\$ 291,733.56	\$ 1,697,024.97

I certify costs claimed by this report are correct and just and based upon actual requirements; that work and services are in accordance with the approved project agreement; and that work and services are satisfactory and consistent with the amount claimed. Supporting documents are attached to verify costs claimed and are available locally for audit and inspection. City, county, or other direct recipients of funds are not involved in any court litigation or lawsuit involving any applicable laws contained in the grant contract

Chief Elected Official Signature

Agnes G. Queen, President
Printed Name of Chief Elected Official

October 10, 2023

*Copies of Invoices Required
Invoice Summary Forms Required*

v1.12.2021

CDBG Invoice Summary-Permits & Fees

Period Covered by Request

04/01/2023-09/18/2023

	Vendor	Invoice #	Description	Inv Date	\$
1.	RHP Resources & Consulting	1113	ROW Agent	7/5/2023	\$ 3,200.00
2.	RHP Resources & Consulting	1116	ROW Agent	8/29/2023	\$ 2,800.00
3.	RHP Resources & Consulting	1117	ROW Agent	9/18/2023	\$ 2,000.00
4.					\$ -
5.					\$ -
6.					\$ -
7.					\$ -
8.					\$ -
9.					\$ -
10.					\$ -
11.					\$ -
12.					\$ -
13.					\$ -
14.					\$ -
15.					\$ -
16.					\$ -
17.					\$ -
18.					\$ -
19.					\$ -
20.					\$ -
PERMITS/FEEES TOTAL					\$ 8,000.00

CDBG Invoice Summary-Administration

Period Covered by Request

04/01/2023-09/18/2023

	Vendor	Invoice #	Description	Inv Date	\$
1.	Region VII Planning & Development Council	451-7	Administration Services - April - June, 2023	6/30/2023	\$ 3,241.47
2.					\$ -
3.					\$ -
4.					\$ -
5.					\$ -
6.					\$ -
7.					\$ -
8.					\$ -
9.					\$ -
10.					\$ -
11.					\$ -
12.					\$ -
13.					\$ -
14.					\$ -
15.					\$ -
16.					\$ -
17.					\$ -
18.					\$ -
19.					\$ -
20.					\$ -
ADMINISTRATION TOTAL					\$ 3,241.47

RHP RESOURCES & CONSULTING
 PO Box 2061
 Buckhannon, West Virginia 26201
 304.472.962
 rhpresources@wvlogic.net

Invoice

Number 1113

Date 7/5/2023

Bill To
 Lewis County EDA
 Ray Smith
 110 Center Avenue
 PO Box 466
 Weston, WV, 26452
 USA

Ship To
 Lewis County EDA
 Ray Smith
 110 Center Avenue
 PO Box 466
 Weston, WV, 26452
 USA

PO Number **Terms** **Project**
 30 days of invoice LCEDA Water Ext Copley, Oil Creek, W

Date	Description	Hours	Rate	Amount
7.01.2023	Oil Creek Franklin Keith Dunn Sheet 71 TM 6N/35	1.00	\$400.00	\$400.00
	Oil Creek Donald Brown Sheet 57 TM 4N/17	1.00	\$400.00	\$400.00
	Oil Creek Harold Helmick Sheet 65 TM 5N/21	1.00	\$400.00	\$400.00
	Oil Creek Harold Helmick Sheet 66 TM 5N/34	1.00	\$400.00	\$400.00
	Oil Creek Harold Helmick Sheet 66 TM 5N/34 Bore Pit	1.00	\$400.00	\$400.00
	Oil Creek Harold Helmick Sheet 67 TM 5N/37	1.00	\$400.00	\$400.00
	Oil Creek Harold Helmick Sheet 67 TM 5N/38	1.00	\$400.00	\$400.00
	Copley Robert Linger Sheet 38 TM 5J/2	1.00	\$400.00	\$400.00

0 - 30 days	31 - 60 days	61 - 90 days	> 90 days	Total
\$3,200.00	\$12,800.00	\$0.00	\$0.00	\$16,000.00

RHP RESOURCES & CONSULTING
 PO Box 2061
 Buckhannon, West Virginia 26201
 304-472-5621
 rhpresources@3wlogic.net

Invoice

Number 1113
 Date 7/5/2023

Bill To
 Lewis County EDA
 Ray Smith
 110 Center Avenue
 PO Box 466
 Weston, WV, 26452
 USA

Ship To
 Lewis County EDA
 Ray Smith
 110 Center Avenue
 PO Box 466
 Weston, WV, 26452
 USA

PO Number **Terms** **Project**
 30 days of Invoice LCEDA Water Ext Copley, Oil Creek, W

Date	Description	Hours	Rate	Amount
------	-------------	-------	------	--------

Amount Paid	\$0.00	Discount	\$0.00
Amount Due	\$3,200.00	Shipping Cost	\$0.00
		Sub Total	\$3,200.00
		Total	\$3,200.00

0 - 30 days	31 - 60 days	61 - 90 days	> 90 days	Total
\$3,200.00	\$12,800.00	\$0.00	\$0.00	\$16,000.00

EQUIPMENT SOURCES AND SERVICES INC
 P.O. Box 466
 Weston, WV, 26452
 (304) 726-3652
 (304) 726-3652 (Fax)
 (304) 726-3652 (Email)

Invoice

Number **1116**
 Date **8/29/2023**

Bill To
 Lewis County EDA
 Ray Smith
 110 Center Avenue
 PO Box 466
 Weston, WV, 26452
 USA

Ship To
 Lewis County EDA
 Ray Smith
 110 Center Avenue
 PO Box 466
 Weston, WV, 26452
 USA

PO Number	Terms	Project
	30 days of invoice	LCEDA Water Ext Copley, Oil Creek, W

Date	Description	Hours	Rate	Amount	
8.29.2023	Copley Area John Bedford Sheet 45 TM 4H/30	1.00	\$400.00	\$400.00	✓
	Copley Area David Ellifritz Sheet 32 TM 5J/34.3	1.00	\$400.00	\$400.00	✓
	Copley Area David Ellifritz Sheet 32 TM 5J/34.3 Bore Pit	1.00	\$400.00	\$400.00	✓
	Copley Area David Ellifritz Sheet 32 TM 5J/36	1.00	\$400.00	\$400.00	✓
	Copley Area David Ellifritz Sheet 32 TM 5J/36 Bore Pit	1.00	\$400.00	\$400.00	✓
	Oil Creek Area Jimmy Brown Sheet 53,54 TM 4P/18.2	1.00	\$400.00	\$400.00	✓
	Oil Creek Area Mark Turley Sheet 95 TM 5P/57.1	1.00	\$400.00	\$400.00	✓

Amount Paid \$0.00
Amount Due \$2,800.00

Discount \$0.00
Shipping Cost \$0.00
Sub Total \$2,800.00

Total \$2,800.00

0 - 30 days	31 - 60 days	61 - 90 days	> 90 days	Total
\$2,800.00	\$3,200.00		\$0.00	

RHP RESOURCES & CONSULTING
 PO Box 2061
 Buckhannon, West Virginia 26201
 304.472.562
 rhpresources@3wlogjc.net

Invoice

Number 1117
 Date 9/18/2023

Bill To
 Lewis County EDA
 Ray Smith
 110 Center Avenue
 PO Box 466
 Weston, WV, 26452
 USA

Ship To
 Lewis County EDA
 Ray Smith
 110 Center Avenue
 PO Box 466
 Weston, WV, 26452
 USA

PO Number Terms Project
 30 days of invoice LCEDA Water Ext Copley, Oil Creek, W

Date	Description	Hours	Rate	Amount
9.18.2023	Whealers Fork Villis Stomers Sheet 102 TM 9M/22	1.00	\$400.00	\$400.00
	Whealers Fork Villis Stomers Sheet 102 TM 9M/22 Bore Pit	1.00	\$400.00	\$400.00
	Oil Creek Area Darel Campbell Sheet 59,60,A24,D38 TM 5N/8	1.00	\$400.00	\$400.00
	Oil Creek Area Steven Posey Sheet 86 TM 5N/20.1	1.00	\$400.00	\$400.00
	Oil Creek Area Steven Posey Sheet 69 TM 5N/50.2	1.00	\$400.00	\$400.00

Amount Paid \$0.00
 Amount Due \$2,000.00

Discount \$0.00
 Shipping Cost \$0.00
 Sub Total \$2,000.00

Total \$2,000.00

0 - 30 days	31 - 60 days	61 - 90 days	> 90 days	Total
\$2,800.00	\$0.00	\$3,200.00		



Region VII Planning and Development Council
 PO Box 849
 Buckhannon, WV 26201

Invoice

Date	Invoice #
6/30/2023	451-7

Bill To
451 Lewis Oil Creek Water Lewis County Commission 110 Center Avenue Weston, WV 26452

Description	Amount
Project Administration Services Invoice For the Period of: April 1, 2023 - June 30, 2023	0.00
Personnel	1,475.49
Fringe Benefits	534.32
Travel	101.53
Telephone	0.00
Postage	0.00
Supplies	0.00
Indirect Costs	1,130.13
	3,241.47
	Total
	\$3,241.47
	Balance Due
	\$3,241.47



T R A V E L L O G R E P O R T
A P R I L 2 0 2 3

451-Lewis Oil Creek Water

Date	Driver	Origin	Destination	Travel Purpose	Start	Finish	Mileage	Mileage Cost
4/27/2023	CLW	BUCKHANNON OFFICE	WESTON	MEETING	15,524	15,574	50	\$32.75
Project Totals:							50	\$32.75



T R A V E L L O G R E P O R T
M A Y 2 0 2 3

451-Lewis Oil Creek Water

Date	Driver	Origin	Destination	Travel Purpose	Start	Finish	Mileage	Mileage Cost
5/4/2023	CLW	BUCKHANNON OFFICE	HORNER	MEETING	16,177	16,210	33	\$21.62
Project Totals:							33	\$21.62

Region VII Planning & Development Council
Travel Expense Account

Employee Cary Smith
 Position Project Manager
 Mailing Address 1852 Mud Lick Road
Buckhannon, WV 26201

0.655

Date	From	Travel To	Return	Mileage	Amount	Hotel	Meals	Other	Describe Other	Total	Grant
5/1/23		-			\$ -	\$ -	\$ -	\$ 50.00	AT&T Fee	\$ 50.00	999
5/15/23	Buckhannon to Lewis County	(Public Meeting)		46	\$ 30.13	\$ -	\$ -	\$ -		\$ 30.13	451
					\$ -	\$ -	\$ -	\$ -		\$ -	
					\$ -	\$ -	\$ -	\$ -		\$ -	
					\$ -	\$ -	\$ -	\$ -		\$ -	
					\$ -	\$ -	\$ -	\$ -		\$ -	
					\$ -	\$ -	\$ -	\$ -		\$ -	
				46	\$ 30.13	\$ -	\$ -	\$ 50.00		\$ 80.13	

Cary A. Smith
Employee

05/16/2023
Date

[Signature]
Executive Director

5/16/23
Date



T R A V E L L O G R E P O R T

J U N E 2 0 2 3

451-Lewis Oil Creek Water

Date	Driver	Origin	Destination	Travel Purpose	Start	Finish	Mileage	Mileage Cost
6/28/2023	CLW	BUCKHANNON OFFICE	WESTON	MEETING	18,349	18,362	13	\$8.52
6/28/2023	CLW	WESTON	BUCKHANNON	MEETING	18,408	18,421	13	\$8.52
Project Totals:							26	\$17.03

Region VII Planning and Development Council
Time by Job Detail
 March 16 through June 15, 2023

3:17 PM
 07/25/2023

451 Lewis Oil Creek Water
 Project Administration

Date	Name	Billing Status	Duration
03/20/2023	Allen, Dionne T	Unbilled	1:00
03/20/2023	Wallace, Carrie L	Unbilled	3:00
03/20/2023	Smith, Cary A	Unbilled	3:30
03/22/2023	Smith, Cary A	Unbilled	1:00
03/24/2023	Smith, Cary A	Unbilled	1:00
03/27/2023	Ball, Peggy L	Unbilled	1:00
03/27/2023	Smith, Cary A	Unbilled	0:00
03/28/2023	Ball, Peggy L	Unbilled	1:00
03/31/2023	Smith, Cary A	Unbilled	1:00
04/03/2023	Wallace, Carrie L	Unbilled	0:30
04/03/2023	Smith, Cary A	Unbilled	0:30
04/04/2023	Wallace, Carrie L	Unbilled	0:30
04/10/2023	Wallace, Carrie L	Unbilled	0:15
04/10/2023	Smith, Cary A	Unbilled	0:00
04/11/2023	Allen, Dionne T	Unbilled	1:00
04/12/2023	Wallace, Carrie L	Unbilled	0:30
04/17/2023	Wallace, Carrie L	Unbilled	1:00
04/17/2023	Smith, Cary A	Unbilled	0:30
04/18/2023	Wallace, Carrie L	Unbilled	0:45
04/24/2023	Smith, Cary A	Unbilled	0:00
04/26/2023	Wallace, Carrie L	Unbilled	0:30
04/26/2023	Smith, Cary A	Unbilled	2:00
04/27/2023	Wallace, Carrie L	Unbilled	4:30
04/27/2023	Smith, Cary A	Unbilled	0:30
05/01/2023	Wallace, Carrie L	Unbilled	1:30
05/01/2023	Smith, Cary A	Unbilled	1:00
05/04/2023	Allen, Dionne T	Unbilled	1:00
05/04/2023	Wallace, Carrie L	Unbilled	4:45
05/08/2023	Wallace, Carrie L	Unbilled	0:45
05/08/2023	Smith, Cary A	Unbilled	0:00
05/15/2023	Smith, Cary A	Unbilled	2:00
05/22/2023	Smith, Cary A	Unbilled	0:00
05/24/2023	Wallace, Carrie L	Unbilled	1:00
05/24/2023	Smith, Cary A	Unbilled	1:00
05/29/2023	Smith, Cary A	Unbilled	0:00
05/31/2023	Wallace, Carrie L	Unbilled	2:00
06/05/2023	Smith, Cary A	Unbilled	0:00
06/06/2023	Allen, Dionne T	Unbilled	1:00
06/07/2023	Wallace, Carrie L	Unbilled	0:30

	Date	Name	Billing Status	Duration
	06/12/2023	Wallace, Carrie L	Unbilled	1:00
	06/12/2023	Smith, Cary A	Unbilled	0:00
Total Project Administration				<u>43:00</u>
Total 451 Lewis Oil Creek Water				<u>43:00</u>
TOTAL				<u><u>43:00</u></u>

AIA[®]

Document G701[®] – 2017

Change Order

PROJECT: <i>(Name and address)</i> Lewis-Gilmer 911 476 US Route 19 North Weston, WV 26452	CONTRACT INFORMATION: Contract For: General Construction Date: 9.21.23	CHANGE ORDER INFORMATION: Change Order Number: 001 Date: 9.21.23
OWNER: <i>(Name and address)</i> County Commission of Lewis County 110 Center Avenue Weston, WV 26452	ARCHITECT: <i>(Name and address)</i> Silling Associates, Inc. 405 Capitol Street, Upper Atrium Charleston, WV 25301	CONTRACTOR: <i>(Name and address)</i> Danhill Construction Company PO Box 685 Gauley Bridge WV 25085

THE CONTRACT IS CHANGED AS FOLLOWS:

(Insert a detailed description of the change and, if applicable, attach or reference specific exhibits. Also include agreed upon adjustments attributable to executed Construction Change Directives.)

This cost proposal is in response to SK "Fire Wall Construction" provided by Moment Engineers, Inc. on 4/24/2023. Danhill Construction Company will proceed with the work described in the SK "Fire Wall Construction" in good faith that this proposal is being submitted as a tracking document for further evaluation during the project. Should cost savings be encountered during construction, those savings shall be applied to this cost proposal.

If work is approved, Danhill Construction Company is requesting (14) fourteen calendar days be added to the contract.

The original Contract Sum was	\$ 6,038,942.00
The net change by previously authorized Change Orders	\$ 0.00
The Contract Sum prior to this Change Order was	\$ 6,038,942.00
The Contract Sum will be increased by this Change Order in the amount of	\$ 9,253.55
The new Contract Sum including this Change Order will be	\$ 6,048,195.55

The Contract Time will be increased by Fourteen (14) days.
 The new date of Substantial Completion will be April 10th, 2024

NOTE: This Change Order does not include adjustments to the Contract Sum or Guaranteed Maximum Price, or the Contract Time, that have been authorized by Construction Change Directive until the cost and time have been agreed upon by both the Owner and Contractor, in which case a Change Order is executed to supersede the Construction Change Directive.

NOT VALID UNTIL SIGNED BY THE ARCHITECT, CONTRACTOR AND OWNER.

Silling Associates, Inc.	Danhill Construction Company	County Commission of Lewis County
ARCHITECT <i>(Firm name)</i>	CONTRACTOR <i>(Firm name)</i>	OWNER <i>(Firm name)</i>
SIGNATURE	SIGNATURE	SIGNATURE
Jeremy Jones, AIA		
PRINTED NAME AND TITLE	PRINTED NAME AND TITLE	PRINTED NAME AND TITLE
9.21.23		
DATE	DATE	DATE

Client: LG911 - Change Order Proposal #01 - EOC 2-HR
Wall Foundation
Property: 476 US Route 19 North
Weston, WV 26452

Operator: JUSTIN_D

Estimator: Justin Dozier
Company: Danhill Construction Company
Business: P.O. Box 685
Gauley Bridge, WV 25085

Cellular: (304) 663-4422
E-mail: justin.
dozier@danhillconstruction.
com

Type of Estimate:

Date Entered: 4/24/2023

Date Assigned:

Price List: WVFA8X_APR23

Labor Efficiency: Restoration/Service/Remodel

Estimate: 2023-04-24-1220

Lewis-Gilmer 911 Call Center
Change Order Proposal #01 - EOC 2-Hr. Wall Foundation

This cost proposal is in response to SK "Fire Wall Construction" provided by Moment Engineers, Inc. on 4/24/2023. Danhill Construction Company will proceed with the work described in the SK "Fire Wall Construction" in good faith that this proposal is being submitted as a tracking document for further evaluation during the project. Should cost savings be encountered during construction, those savings shall be applied to this cost proposal.

If work is approved, Danhill Construction Company is requesting (14) fourteen calendar days be added to the contract.

Respectfully,

Justin Dozier
Project Manager
Danhill Construction Company

2023-04-24-1220

Bond Increase (DHC)*

CAT	SEL	ACT DESCRIPTION		REMOVE	REPLACE	TAX	O&P	TOTAL
	CALC	QTY						
1. FEE	TIPF	+ Bond Increase (2%)						
	0.02	0.02 EA	[*EN]	0.00+	9,245.48 =	0.00	0.00	184.91
Totals: Bond Increase (DHC)*						0.00	0.00	184.91

Insurance Increase (DHC)*

CAT	SEL	ACT DESCRIPTION		REMOVE	REPLACE	TAX	O&P	TOTAL
	CALC	QTY						
2. FEE	TIPF	+ Insurance Increase (1%)						
	0.01	0.01 EA	[*EN]	0.00+	9,245.48 =	0.00	0.00	92.45
Totals: Insurance Increase (DHC)*						0.00	0.00	92.45

Concrete Saw Cutting (DHC)*

CAT	SEL	ACT DESCRIPTION		REMOVE	REPLACE	TAX	O&P	TOTAL
	CALC	QTY						
3. CNC	SAWSL	I Concrete cutting - slab (per LF per inch of saw depth) (Equipment & Labor)						
	125*5	625.00 LF		0.00+	2.51 =	0.00	235.32	1,804.07
Totals: Concrete Saw Cutting (DHC)*						0.00	235.32	1,804.07

Concrete Demolition & Excavation (DHC)*

CAT	SEL	ACT DESCRIPTION		REMOVE	REPLACE	TAX	O&P	TOTAL
	CALC	QTY						
4. EXC	LAB	I Concrete Demolition & Excavation for Foundation - Equipment Operator (Labor)						
	10	10.00 HR		0.00+	60.27 =	0.00	90.41	693.11
5. EXC	LABL	I Concrete Demolition & Excavation for Foundation - General Laborer (Labor)						
	2*10	20.00 HR	[*]	0.00+	55.00 =	0.00	165.00	1,265.00

CONTINUED - Concrete Demolition & Excavation (DHC)*

CAT	SEL	ACT DESCRIPTION		REMOVE	REPLACE	TAX	O&P	TOTAL
	CALC	QTY						
Totals: Concrete Demolition & Excavation (DHC)*						0.00	255.41	1,958.11

Concrete Reinforcement (DHC)*

CAT	SEL	ACT DESCRIPTION		REMOVE	REPLACE	TAX	O&P	TOTAL
	CALC	QTY						
6. CNC	RB4		M Material Only Foundation - Dowels - Steel rebar - #4 (1/2") (Material)					
	120	120.00 LF		0.00+	0.93 =	0.00	16.74	128.34
7. CNC	RB4		I Install Foundation - Dowels - Steel rebar - #4 (1/2") (Installation)					
	120	120.00 LF		0.00+	0.62 =	0.00	11.16	85.56
8. CNC	RB5		M Material Only Foundation - Longitudinal - Steel rebar - #5 (5/8") (Material)					
	125*3*1.15	431.25 LF		0.00+	1.10 =	0.00	71.16	545.54
9. CNC	RB5		I Install Foundation - Longitudinal - Steel rebar - #5 (5/8") (Installation)					
	125*3*1.15	431.25 LF		0.00+	0.93 =	0.00	60.16	461.22
10. CNC	RB4		M Material Only Foundation - Transverse/Tie - Steel rebar - #4 (1/2") (Material)					
	120	120.00 LF		0.00+	0.93 =	0.00	16.74	128.34
11. CNC	RB4		I Install Foundation - Transverse/Tie - Steel rebar - #4 (1/2") (Installation)					
	120	120.00 LF		0.00+	0.62 =	0.00	11.16	85.56
12. CNC	RBJ53		M Material Only Steel rebar - j-bar - #5, 3' 6" (Material)					
	32	32.00 EA		0.00+	2.47 =	0.00	11.85	90.89
13. CNC	RBJ53		I Install Steel rebar - j-bar - #5, 3' 6" (Installation)					
	32	32.00 EA		0.00+	3.03 =	0.00	14.55	111.51
Totals: Concrete Reinforcement (DHC)*						0.00	213.52	1,636.96

Concrete (DHC)*

CAT	SEL	ACT DESCRIPTION		REMOVE	REPLACE	TAX	O&P	TOTAL
	CALC	QTY						
14. CNC	SLCY		M Material Only Concrete Foundation for 2-hr Fire Wall (Material)					
	8	8.00 CY [*]		0.00+	200.00 =	0.00	240.00	1,840.00
15. CNC	SLCY		I Install Concrete Foundation for 2-hr Fire Wall (Installation)					
	8	8.00 CY		0.00+	188.81 =	0.00	226.57	1,737.05
Totals: Concrete (DHC)*						0.00	466.57	3,577.05

Line Item Totals: 2023-04-24-1220

0.00

1,170.82

9,253.55

Summary

Line Item Total	8,082.73
Overhead	780.55
Profit	390.27
	<hr/>
Replacement Cost Value	\$9,253.55
Net Claim	\$9,253.55
	<hr/> <hr/>

Justin Dozier 4/24/2023
Justin Dozier

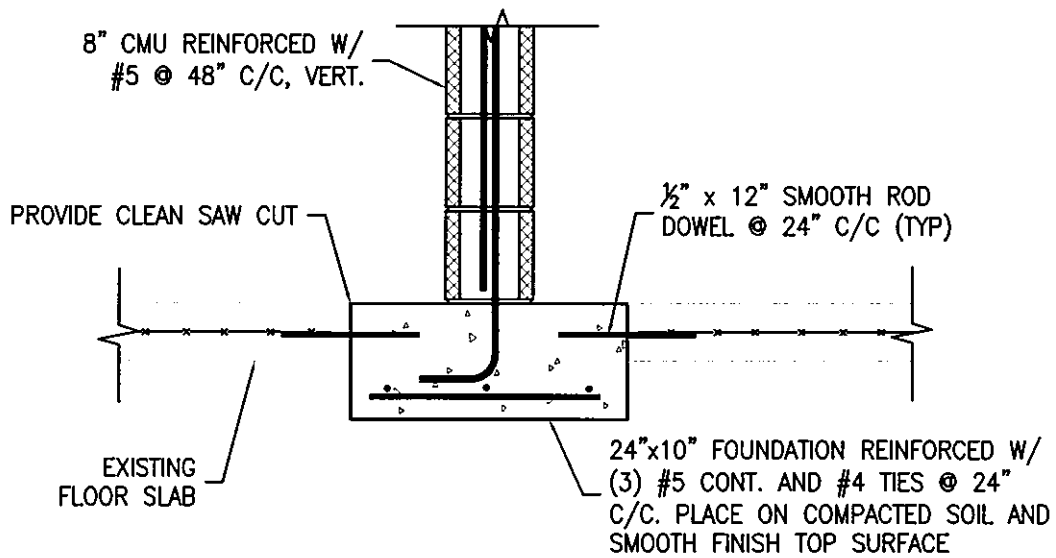
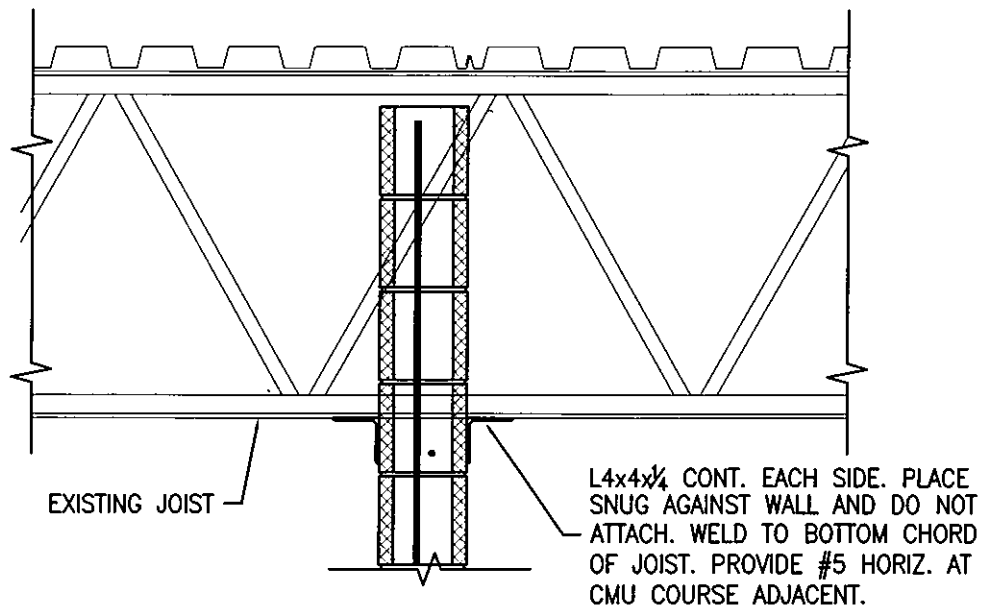

MOMENT
engineers, inc.

2301 Windham Road
So. Charleston, WV 25303
304.414.4000
www.momentengineers.com

LEWIS-GILMER COUNTY
911 CALL CENTER & EMERGENCY
MANAGEMENT OFFICES
WESTON, WV

FIRE WALL CONSTRUCTION

by: DRR

date: 4/24/23

scale: 3/4" = 1'-0"



AIA[®]

Document G701[®] – 2017

Change Order

PROJECT: *(Name and address)*
Lewis-Gilmer 911
476 US Route 19 North
Weston, WV 26452

CONTRACT INFORMATION:
Contract For: General Construction
Date: 9.21.23

CHANGE ORDER INFORMATION:
Change Order Number: 003
Date: 9.21.23

OWNER: *(Name and address)*
County Commission of Lewis County
110 Center Avenue
Weston, WV 26452

ARCHITECT: *(Name and address)*
Silling Associates, Inc.
405 Capitol Street, Upper Atrium
Charleston, WV 25301

CONTRACTOR: *(Name and address)*
Danhill Construction Company
PO Box 685
Gauley Bridge WV 25085

THE CONTRACT IS CHANGED AS FOLLOWS:

(Insert a detailed description of the change and, if applicable, attach or reference specific exhibits. Also include agreed upon adjustments attributable to executed Construction Change Directives.)

Abatement required for hazardous materials (asbestos) discovered during demolition.

The original Contract Sum was	\$ 6,038,942.00
The net change by previously authorized Change Orders	\$ 32,936.67
The Contract Sum prior to this Change Order was	\$ 6,071,878.67
The Contract Sum will be increased by this Change Order in the amount of	\$ 12,608.00
The new Contract Sum including this Change Order will be	\$ 6,084,486.67

The Contract Time will be increased by Fourteen (14) days.
The new date of Substantial Completion will be June 8th, 2024

NOTE: This Change Order does not include adjustments to the Contract Sum or Guaranteed Maximum Price, or the Contract Time, that have been authorized by Construction Change Directive until the cost and time have been agreed upon by both the Owner and Contractor, in which case a Change Order is executed to supersede the Construction Change Directive.

NOT VALID UNTIL SIGNED BY THE ARCHITECT, CONTRACTOR AND OWNER.

Silling Associates, Inc.
ARCHITECT *(Firm name)*

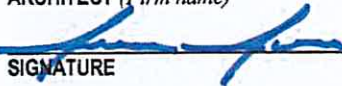
SIGNATURE

Jeremy Jones, AIA
PRINTED NAME AND TITLE

9.21.23
DATE

Danhill Construction Company
CONTRACTOR *(Firm name)*

SIGNATURE

PRINTED NAME AND TITLE

DATE

County Commission of Lewis County
OWNER *(Firm name)*

SIGNATURE

PRINTED NAME AND TITLE

DATE

Client: LG911 Change Order Proposal #3 - Asbestos
Abatement
Property: 476 US Route 19 North
Weston, WV 26452

Operator: JUSTIN_D

Estimator: Justin Dozier
Company: Danhill Construction Company
Business: P.O. Box 685
Gauley Bridge, WV 25085

Cellular: (304) 663-4422
E-mail: justin.
dozier@danhillconstruction.
com

Type of Estimate:

Date Entered: 9/20/2023

Date Assigned:

Price List: WVFA8X_SEP22

Labor Efficiency: Restoration/Service/Remodel

Estimate: 2023-09-20-1910

Danhill Construction is requesting (14) days be added to the contract should this change order proposal be accepted. If abatement is accepted, a (10) day notification period will take place prior to abatement activities taking place.

2023-09-20-1910

Asbestos Abatement (Astech Corporation)*

CAT	SEL	ACT DESCRIPTION	REMOVE	REPLACE	TAX	TOTAL
	CALC	QTY				
1. HMR	AGP	+ Asbestos Abatement - Show Room Roof				
		1 1.00 EA [*]	0.00+	6,600.00 =	0.00	6,600.00
2. IIMR	AGP	+ Asbestos Abatement - Office, Garage, and Show Room Floor Tile & Mastic				
		1 1.00 EA [*]	0.00+	5,558.00 =	0.00	5,558.00
3. HMR	AGP	+ Asbestos Abatement - (3) Steel Framed Windows				
		1 1.00 EA [*]	0.00+	450.00 =	0.00	450.00
Totals: Asbestos Abatement (Astech Corporation)*					0.00	12,608.00
Line Item Totals: 2023-09-20-1910					0.00	12,608.00

Summary

Line Item Total	12,608.00
Replacement Cost Value	\$12,608.00
Net Claim	\$12,608.00

Justin Dozier
Justin Dozier

Astech Corporation

3400 Falcon Drive
Charleston WV 25312
304-342-0545

Contractor License: WV008876

Email: astech51@hotmail.com

04-28-2023

Justin Dozier
Danhill Construction Co.
Cell: 304-663-4422
Office: 304-632-1600
PO Box 685
Gauley Bridge, WV 25085
Email justin_dozier@yahoo.com

RE: Lewis Gilmore 911 Call Center

PROPOSAL

We propose to do the asbestos removal from the above reference site as follows.

1. Main Garage Roof	\$29,700.00
2. Show Room Roof	6,600.00
3. Office, Garage, Show Room Floor Tile	5,558.00
4. 3 Steel Frame Windows	450.00
5. Main Garage Roof Coordinated with Roofer	34,200.00
6. Show Room Roof Coordinated with Roofer	7,500.00

This will include all notifications, permits, labor, material and disposal fees.

Sincerely,

Denver Davis



AIA® Document G701® – 2017

Change Order

PROJECT: *(Name and address)*
Lewis-Gilmer 911
476 US Route 19 North
Weston, WV 26452

CONTRACT INFORMATION:
Contract For: General Construction
Date: 9.21.23

CHANGE ORDER INFORMATION:
Change Order Number: 002
Date: 9.21.23

OWNER: *(Name and address)*
County Commission of Lewis County
110 Center Avenue
Weston, WV 26452

ARCHITECT: *(Name and address)*
Silling Associates, Inc.
405 Capitol Street, Upper Atrium
Charleston, WV 25301

CONTRACTOR: *(Name and address)*
Danhill Construction Company
PO Box 685
Gauley Bridge WV 25085

THE CONTRACT IS CHANGED AS FOLLOWS:

(Insert a detailed description of the change and, if applicable, attach or reference specific exhibits. Also include agreed upon adjustments attributable to executed Construction Change Directives.)

1 mobilization

2 layer of stabilization

1st layer is 50,000 lbs (approximately 7.5 lbs/SF) of cement mixed into the soil with an excavator to an approximate depth of 2 feet and compact as best we can with sheeps foot roller.

2nd layer is 50,000 lbs of cement mixed with traditional stabilizing equipment to a depth of 12 inches. Supplying and spreading of cement

Mixing of cement treated subbase

Hauling and mixing of water for proper moisture control if required Compacting of subbase with a sheep's foot roller

Fine Grading after compaction to subgrade

Smooth Drum Rolling after fine grading.

The original Contract Sum was	\$	6,038,942.00
The net change by previously authorized Change Orders	\$	9,253.55
The Contract Sum prior to this Change Order was	\$	6,048,195.55
The Contract Sum will be increased by this Change Order in the amount of	\$	23,683.12
The new Contract Sum including this Change Order will be	\$	6,071,878.67

The Contract Time will be increased by Forty-five (45) days.

The new date of Substantial Completion will be May 25th, 2024

NOTE: This Change Order does not include adjustments to the Contract Sum or Guaranteed Maximum Price, or the Contract Time, that have been authorized by Construction Change Directive until the cost and time have been agreed upon by both the Owner and Contractor, in which case a Change Order is executed to supersede the Construction Change Directive.

NOT VALID UNTIL SIGNED BY THE ARCHITECT, CONTRACTOR AND OWNER.

Silling Associates, Inc.
ARCHITECT *(Firm name)*

Danhill Construction Company
CONTRACTOR *(Firm name)*

County Commission of Lewis County
OWNER *(Firm name)*

SIGNATURE

SIGNATURE

SIGNATURE

Jeremy Jones, AIA
PRINTED NAME AND TITLE

PRINTED NAME AND TITLE

PRINTED NAME AND TITLE

9.21.23
DATE

DATE

DATE

Danhill Construction Company

Client: LG 911 - Change Order #2 - Cement Stabilization
Property: 476 US Route 19 North
Weston, WV 26452

Operator: JUSTIN_D

Estimator: Justin Dozier
Company: Danhill Construction Company
Business: P.O. Box 685
Gauley Bridge, WV 25085

Cellular: (304) 663-4422
E-mail: justin.
dozier@danhillconstruction.
com

Type of Estimate:

Date Entered: 7/5/2023

Date Assigned:

Price List: WVFA8X_JUL23

Labor Efficiency: Restoration/Service/Remodel

Estimate: 2023-07-05-0705

Lewis-Gilmer 911 Call Center

Change Order Proposal #2 - Cement Stabilization - Attempt #2

Change Order Proposal #2 - Scope of Work

Includes:

1 mobilization

2 layer of stabilization

1st layer is 50,000 lbs (approximately 7.5 lbs/SF) of cement mixed into the soil with an excavator to an approximate depth of 2 feet and compact as best we can with sheeps foot roller.

2nd layer is 50,000 lbs of cement mixed with traditional stabilizing equipment to a depth of 12 inches.

Supplying and spreading of cement

Mixing of cement treated subbase

Hauling and mixing of water for proper moisture control if required

Compacting of subbase with a sheep's foot roller

Fine Grading after compaction to subgrade

Smooth Drum Rolling after fine grading.

Change Order Proposal #2 - Breakdown of Pricing

Allowance #1 - Cement Stabilization - See SOV	\$35,175.00
Wolfe's Excavating - Cement Stabilization - Attempt #1	(\$21,305.86)
Wolfe's Excavating - Cement Stabilization - Attempt #1 - GC Overhead & Profit	(\$ 3,195.88)
Balance of Allowance #1 - Cement Stabilization	\$10,673.26

Ryanes & Co., LLC - Cement Stabilization - Attempt #2	\$22,225.75
---	-------------

Bond Increase - 2%	\$ 473.25
--------------------	-----------

Insurance Increase - 1%	\$ 236.62
-------------------------	-----------

Project Management & Coordination	\$ 747.50
-----------------------------------	-----------

Change Order Proposal #2 Total	\$23,683.12
--------------------------------	-------------

* Note: The remaining balance of Allowance #1 - Cement Stabilization in the amount \$10,673.26 has been applied to the \$30,000.00 proposal received from Raynes and Company, LLC

*Danhill Construction Company is requesting (45) forty-five days be added to the contract to allow subsurface conditions and site to dry prior to second round of cement stabilization.

Danhill Construction Company

Respectfully Submitted,

Justin Dozier

Justin Dozier

Project Manager

Danhill Construction Company

Danhill Construction Company

2023-07-05-0705

Bond Increase (DHC)*

CAT	SEL	ACT DESCRIPTION		REMOVE	REPLACE	TAX	O&P	TOTAL
	CALC	QTY						
1. FEE	TIPF		+ Bond Increase (2%)					
	0.02	0.02 EA [*EN]		0.00+	23,662.45 =	0.00	0.00	473.25
Totals: Bond Increase (DHC)*						0.00	0.00	473.25

Insurance Increase (DHC)*

CAT	SEL	ACT DESCRIPTION		REMOVE	REPLACE	TAX	O&P	TOTAL
	CALC	QTY						
2. FEE	TIPF		+ Insurance Increase (1%)					
	0.01	0.01 EA [*EN]		0.00+	23,662.45 =	0.00	0.00	236.62
Totals: Insurance Increase (DHC)*						0.00	0.00	236.62

Project Management & Coordination (DHC)

*

CAT	SEL	ACT DESCRIPTION		REMOVE	REPLACE	TAX	O&P	TOTAL
	CALC	QTY						
3. LAB	ADMIN		+ Project Management & Coordination					
	10	10.00 HR [*]		0.00+	65.00 =	0.00	97.50	747.50
Totals: Project Management & Coordination (DHC)*						0.00	97.50	747.50

Cement Stabilization - 2nd Attempt (Raynes & Co)*

CAT	SEL	ACT DESCRIPTION		REMOVE	REPLACE	TAX	O&P	TOTAL
	CALC	QTY						
4. CNC	STBCHGM		+ Cement Stabilization - 2nd Attempt (Raynes & Company, LLC)					
	1	1.00 EA [*]		0.00+	19,326.74 =	0.00	2,899.01	22,225.75

Danhill Construction Company

CONTINUED - Cement Stabilization - 2nd Attempt (Raynes & Co)*

CAT	SEL	ACT DESCRIPTION	REMOVE	REPLACE	TAX	O&P	TOTAL
	CALC	QTY					
Totals: Cement Stabilization - 2nd Attempt (Raynes & Co)*					0.00	2,899.01	22,225.75
Line Item Totals: 2023-07-05-0705					0.00	2,996.51	23,683.12

Summary

Line Item Total	20,686.61
Overhead	1,997.67
Profit	998.84
	<hr/>
Replacement Cost Value	\$23,683.12
Net Claim	\$23,683.12
	<hr/> <hr/>

Justin Dozier 7/5/2023
Justin Dozier



WOLFE'S EXCAVATING LLC

23-LGSTABIL 23-LEWIS GILMER STABILIZATION

05/18/2023 3:10 PM

BID PROPOSAL

Bid Item	Description	Quantity	Units	Unit Price	Bid Total
10	MOBILIZATION	1.000	LS	1,185.76	1,185.76
20	SOIL CEMENT STABILIZATION (7LBS/SF IN SPECS)	7.035.000	SF	2.86	20,120.10
Bid Total					\$21,305.86

1. Grading and compaction by others.
2. 25 total tons of cement is included in line 20, per specifications.
3. 7 lb/sf cement application rate, per specifications.
4. Pricing is unit based and will be billed at a unit rate.
5. Any work not priced is not included.

Respectfully,

Trent Shepherd
 304-771-7906
 tshepherd@wolfesexcavating.com

Proposal Accepted
 Justin Dozier,
 Project Manger
 5/22/2023

Raynes & Company, LLC

Route 62, PO Box 438
Eleanor, West Virginia 25070
Phone: 304-586-2535
Fax: 888-463-3087
WV License # WV046302

6-29-2023

Stabilization Pricing for Lewis County 911 in Weston, WV.

- Cement Stabilization \$ 30,000

Includes:

1 mobilization

2 layer of stabilization

1st layer is 50,000 lbs (approximately 7.5 lbs/SF) of cement mixed into the soil with an excavator to an approximate depth of 2 feet and compact as best we can with sheeps foot roller.

2nd layer is 50,000 lbs of cement mixed with traditional stabilizing equipment to a depth of 12 inches.

Supplying and spreading of cement

Mixing of cement treated subbase

Hauling and mixing of water for proper moisture control if required

Compacting of subbase with a sheep's foot roller

Fine Grading after compaction to subgrade

Smooth Drum Rolling after fine grading.

Price does not include:

Geotesting or lab work

Any mass excavation

Moving of any excess material

Removal and replacement of any material

Layout or stake out of any kind

Supplying of a water source (minimum 2")

Water Curing of stabilization if required

- Additional Cement for excessive soft and excessively wet areas \$ 450/ton
- Minimum of a 25 ton truck load is required

➤ All pricing is given:

Dewatering pumps will be maintained prior to stabilization and for a minimum of 72 hours after stabilization.

Puddled water will be drained or pumped as much as possible prior to mobilization.

Dirt elevation will be within .1 foot of subgrade upon mobilization. 2" Water source is at the site and easily accessible with a water truck.

Heavy equipment and track equipment should stay off of cement treated base for a minimum of 72 hrs.

~~Excavation of Rear Slope Behind Building \$12,000~~

~~Includes:~~

~~Excavate slope to staked elevations~~

~~Load out of excess material on Dan Hill Trucks.~~

~~Hydroseed slope.~~

~~Roll straw matting on slope.~~

~~Excludes:~~

~~ANY WARRANTY OR GUARANTEE SLOPE WILL STAY!~~

~~ANY GUARANTEE GRASS WILL GROW. (As it is outside of seeding season)~~

~~Any work above property line.~~

- ❖ If there are any questions or additional items you would like me to price please call me at 304-545-1468.

Thanks,

Josh Raynes



AIA® Document G701® – 2017

Change Order

PROJECT: *(Name and address)*
Lewis-Gilmer 911
476 US Route 19 North
Weston, WV 26452

CONTRACT INFORMATION:
Contract For: General Construction
Date: 10.3.23

CHANGE ORDER INFORMATION:
Change Order Number: 004
Date: 10.3.23

OWNER: *(Name and address)*
County Commission of Lewis County
110 Center Avenue
Weston, WV 26452

ARCHITECT: *(Name and address)*
Silling Associates, Inc.
405 Capitol Street, Upper Atrium
Charleston, WV 25301

CONTRACTOR: *(Name and address)*
Danhill Construction Company
PO Box 685
Gauley Bridge WV 25085

THE CONTRACT IS CHANGED AS FOLLOWS:

(Insert a detailed description of the change and, if applicable, attach or reference specific exhibits. Also include agreed upon adjustments attributable to executed Construction Change Directives.)

Scope modifications made in Bulletin #2 - CMU reductions, framing increases, & envelope reductions.

The original Contract Sum was	\$	6,038,942.00
The net change by previously authorized Change Orders	\$	44,544.67
The Contract Sum prior to this Change Order was	\$	6,083,486.67
The Contract Sum will be decreased by this Change Order in the amount of	\$	13,933.17
The new Contract Sum including this Change Order will be	\$	6,069,553.50

The Contract Time will be unchanged by Zero (0) days.
The new date of Substantial Completion will be June 8th, 2024

NOTE: This Change Order does not include adjustments to the Contract Sum or Guaranteed Maximum Price, or the Contract Time, that have been authorized by Construction Change Directive until the cost and time have been agreed upon by both the Owner and Contractor, in which case a Change Order is executed to supersede the Construction Change Directive.

NOT VALID UNTIL SIGNED BY THE ARCHITECT, CONTRACTOR AND OWNER.

Silling Associates, Inc.
 ARCHITECT *(Firm name)*

 SIGNATURE

 Jeremy Jones, AIA
 PRINTED NAME AND TITLE

 9.29.23
 DATE

Danhill Construction Company
 CONTRACTOR *(Firm name)*

 SIGNATURE

 PRINTED NAME AND TITLE

 DATE

County Commission of Lewis County
 OWNER *(Firm name)*

 SIGNATURE

 PRINTED NAME AND TITLE

 DATE

Danhill Construction Company

Client: LG911 - Change Order Proposal #4 - Bulletin #2
Property: 476 US Route 19 North
Weston, WV 26452

Operator: JUSTIN_D

Estimator: Justin Dozier
Company: Danhill Construction Company
Business: P.O. Box 685
Gauley Bridge, WV 25085

Cellular: (304) 663-9065
E-mail: justin.
dozier@danhillconstruction.
com

Type of Estimate:

Date Entered: 9/25/2023

Date Assigned:

Price List: WVFA8X_SEP22

Labor Efficiency: Restoration/Service/Remodel

Estimate: 2023-09-25-1257

Danhill Construction Company

2023-09-25-1257

General Conditions (DHC)*

CAT	SEL	ACT DESCRIPTION		REMOVE	REPLACE	TAX	TOTAL
	CALC	QTY					
1. FEE	TIPF		+ Bond Decrease - Deduct (2%)				
	1	1.00 EA [*]		0.00+	273.20 =	0.00	(273.20)
Totals: General Conditions (DHC)*						0.00	(273.20)

Selective Demolition (DHC)*

CAT	SEL	ACT DESCRIPTION		REMOVE	REPLACE	TAX	TOTAL
	CALC	QTY					
2. DMO	LAB		- Bulletin #2 - Additional Masonry Demolition (Danhill Construction Company)				
	3*10	30.00 HR [*]		55.00+	0.00 =	0.00	1,650.00
3. FEE	TIPF		+ General Contractor's Overhead & Profit - Add (5%)				
	0.05	0.05 EA [*]		0.00+	1,650.00 =	0.00	82.50
Totals: Selective Demolition (DHC)*						0.00	1,732.50

Masonry (Mardo Masonry)*

CAT	SEL	ACT DESCRIPTION		REMOVE	REPLACE	TAX	TOTAL
	CALC	QTY					
4. MAS	AGP		+ Bulletin #2 - Frame parapet in lieu of CMU (Mardo Masonry)				
	1	1.00 EA [*]		0.00+	3,100.00 =	0.00	(3,100.00)
5. FEE	TIPF		+ General Contractor's Profit - Deduct (5%)				
	0.05	0.05 EA [*]		0.00+	3,100.00 =	0.00	(155.00)
Totals: Masonry (Mardo Masonry)*						0.00	(3,255.00)

Framing & Facade Changes (J&J Drywall)*

Framing & Facade Changes (J&J Drywall)*

CAT	SEL	ACT DESCRIPTION		REMOVE	REPLACE	TAX	TOTAL
	CALC	QTY					
6. FRM	AGP		+ Bulletin #2 - Framing & Facade Changes (J&J Drywall)				
	1	1.00 EA [*]		0.00+	15,762.00 =	0.00	(15,762.00)

Danhill Construction Company

CONTINUED - Framing & Facade Changes (J&J Drywall)*

CAT	SEL CALC	ACT DESCRIPTION QTY	REMOVE	REPLACE	TAX	TOTAL
7. FEE	TIPF 0.05	+ General Contractor's Profit - Deduct (5%) 0.05 EA [*]	0.00+	15,762.00 =	0.00	(788.10)
Total: Framing & Facade Changes (J&J Drywall)*					0.00	(16,550.10)

Aluminum Storefronts (Premier Glass)*

CAT	SEL CALC	ACT DESCRIPTION QTY	REMOVE	REPLACE	TAX	TOTAL
8. DOR	AGP 1	+ Bulletin #2 - MK 017 - Opening Size Increased (Premier Glass) 1.00 EA [*]	0.00+	2,452.50 =	0.00	2,452.50
9. FEE	TIPF 0.05	+ General Contractor's Overhead & Profit - Add (5%) 0.05 EA [*]	0.00+	2,452.50 =	0.00	122.63
Totals: Aluminum Storefronts (Premier Glass)*					0.00	2,575.13

Painting (A.J. Vater & Co., Inc.)*

CAT	SEL CALC	ACT DESCRIPTION QTY	REMOVE	REPLACE	TAX	TOTAL
10. PNT	AGP 1	+ Bulletin #2 - Additional Facade Painting (A.J. Vater & Co., Inc) 1.00 EA [*]	0.00+	1,750.00 =	0.00	1,750.00
11. FEE	TIPF 0.05	+ General Contractor's Overhead & Profit - Add (5%) 0.05 EA [*]	0.00+	1,750.00 =	0.00	87.50
Totals: Painting (A.J. Vater & Co., Inc.)*					0.00	1,837.50

Line Item Totals: 2023-09-25-1257 0.00 (S13,933.17)

Summary

Line Item Total	(\$13,933.17)
Replacement Cost Value	(\$13,933.17)
Net Claim	(\$13,933.17)

Justin Dozier 9-25-2023
Justin Dozier



JJ & DRYWALL, INC

Interior Systems Contractor

2411 Pike Drive
Fairmont, WV 26554
304-367-0443 304-367-0400/ Fax
WV Contractor #: WV024640

PROPOSAL

DATE: TUESDAY, SEPTEMBER 5, 2023

JOB NAME: Lewis Gilmer 911 Call Center/ Base

Bulletin #2

JOB #:

JOB ADDRESS: 479 US HWY 19 N

Weston, WV 26452

TO: DAN HILL CONSTRUCTION COMPANY

Attention: Justin Dozier

Address: PO Box 685 Gauley Bridge, WV 25085

Phone:

Fax:

PROPOSAL SUMMARY

CONDITIONS

05400 Cold Formed Metal Framing:

06160 Exterior Sheathing:

07272 Fluid Applied Air Barrier:

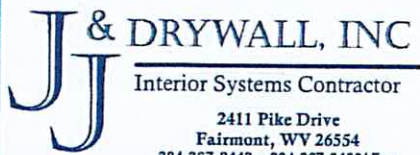

JJ & DRYWALL, INC

Interior Systems Contractor

2411 Pike Drive
Fairmont, WV 26554
304-367-0443 304-367-0400/ Fax
WV Contractor #: WV024640

PROPOSAL

07400 Fiber Cement Siding:

07450 Fiber Reinforced Cementous Panels:

07462 Thermal and Air Barrier:

BULLETIN 2 TOTAL

BULLETIN 2 AMOUNT: -15,762

J & DRYWALL, INC
J J
Interior Systems Contractor
2411 Pike Drive
Fairmont, WV 26554
304-367-0443 Fax 304-367-0400

Lewis Gilmer 911 Center

Bulletin #2 Changes

Sheet A3.1- Changed footprint of "Future Offices" of EOC building from 43' x 14'-1" to 42' x 12'-10".

Sheet A5.0- Changed height of admin wing from 14' to 12'-6".
Deleted 36'-9" linear feet of cladding on West Elevation.
Deleted Nichiha return @ South Elevation.
Deleted Nichiha return @ North Elevation.

Sheet A6.0- Section 5, change height of Admin from 14' to 12'-6".
Section 6, change header & sill elevation on West Elevation.

Sheet A7.3- Shows height change @ EOC Admin from 14' to 12'-6"

Sheet A7.4- Change height of Admin from 14' to 12'-6".
Change header & sill elevation heights.

Sheet A7.5- Change height of Admin from 14' to 12'-6".
Change header & sill elevation heights.

Sheet A7.6- Change height of Admin from 14' to 12'-6".

Sheet A8.3- Detail 3, Parapet height change of 1'-6".

Sheet A8.4- Change header & sill elevation heights.

Sheet A8.5- Add 6" box headers.

Sheet A8.6- Add 6" box headers and framing.

Sheet A9.2- Added 10" to Door 107.

Sheet A9.3- Lower window elevation 1'-6".



**PREMIER
GLASS**

EST. 2021

**Lewis Gilmer 911 Center 9/12/23
Scope Change MK 107 - 3076 Aluminum Door**

We propose to furnish + install the exterior storefront & in EFCO material to meet or exceed the job spec.

All glass to meet or exceed spec. All glass will be provided by UPG & glazed by Premier Glass LLC.

Lot Total - \$2,250.00

Total with tax + B&O - \$2,452.50

Labor (Includes install, glazing, caulking & clean up.)

Adam Funk

Contractor ID WV060609

304-695-0028

Info@premierglasswv.com

P.O Box 1207 Clarksburg, WV 26302



	A.J. VATER & CO.,INC.		
	412-331-4477 PHONE / 412-331-9625 FAX		
	412-559-2112 CELL / DAN@AJVATER.COM		
	WV CONTRACTORS LICENSE # WV001397		
TO:	MR JUSTIN DOZIER		5/23/2023
PROJECT:	LEWIS GILMER 911 - BULLETIN 2		
ARCHITECT:			
PLAN DATE:		SHEET NO:	ARCHITECTURAL
SPEC DATE:		SECTIONS:	PAINING
ADDENDUMS:		ESTIMATOR:	DAN VATER
BASE BID:	ADD \$1,750.00		
ALTERNATE:			
REMARKS:	ADDITIONAL PAINTING EXTERIOR OF EOC BUILDING.		

srogers lewiscountywv.org

From: Tina Helmick
Sent: Thursday, September 28, 2023 1:49 PM
To: srogers lewiscountywv.org
Subject: FW: Spay/Neuter Funds

Please add this \$5,000 request to the next agenda.

From: lwhetsell lewiscountywv.org <lwhetsell@lewiscountywv.org>
Sent: Thursday, September 28, 2023 1:46 PM
To: Tina Helmick <thelmick@lewiscountywv.org>; aqueen4500@aol.com; bobbystewart00@gmail.com; 'centralwv@yahoo.com' <centralwv@yahoo.com>
Subject: Re: Spay/Neuter Funds

You just need to put it on the agenda for approval. The money is in Upshur County for both counties. The need LCC approval since it is joint. Won't be any checks coming from Lewis

From: Tina Helmick <thelmick@lewiscountywv.org>
Sent: Thursday, September 28, 2023 11:36 AM
To: aqueen4500@aol.com <aqueen4500@aol.com>; bobbystewart00@gmail.com <bobbystewart00@gmail.com>; 'centralwv@yahoo.com' <centralwv@yahoo.com>
Cc: lwhetsell lewiscountywv.org <lwhetsell@lewiscountywv.org>
Subject: FW: Spay/Neuter Funds

FYI...Cindy can you guide me on this??

From: jcochran@upshurcounty.org <jcochran@upshurcounty.org>
Sent: Thursday, September 28, 2023 11:29 AM
To: Tina Helmick <thelmick@lewiscountywv.org>
Subject: Spay/Neuter Funds

Tina,

I think before you took over Cindy's position, the shelter had requested \$5000 from the commission from the spay/neuter account. We have used up the funds that the commission allowed us to have and now we are asking that the commission consider letting the shelter have another \$5000 from this account. This money comes from the spay/neuter deposit of adopters and is forfeited if not used in a certain time frame. This fund can only be used for spay/neuter of animals and for spay/neuter education. We have noticed if we are able to spay/neuter the animals that come into the pound prior to their adoption, that we are can find them new forever homes much quicker. Unfortunately the whole nation is seeing a huge decrease in adoptions and euthanasia rates are climbing everywhere but we have found that by fixing the animals first it helps out the adopters and rescue groups we work with and enables us to move more animals out safely.

Appreciate the consideration of this request,
Jan Cochran
Supervisor of Animal Services
Lewis-Upshur Animal Control Facility
304-472-3865

From: crowan lewiscountywv.org
Sent: Monday, September 25, 2023 1:02 PM
To: Tina Helmick; srogers lewiscountywv.org
Subject: For October 10, 2023 Agenda

I have to bring to October 10th meeting the 2022 Tax List.

David B. Gosa, Sheriff of Lewis County, presents the 2022 Delinquent Tax list for approval by the Lewis County Commission. This list will be published in the Weston Democrat, if approved.

Cindy